



PRESTWICK
GOLF GROUP

"The Prestwick Golf Group used state-of-the-art logo application, laser engraving, on their Keystone design. They accurately portrayed our intricate logo on furnishings that, to this day, continue to perform. The Prestwick Golf Group fit our image of tradition and respect for the game."

Mike O'Reilly, Head Golf Professional
Whistling Straits, site of the 2010 PGA Championship

Table of Contents

Prestwick Golf Group	2
Our Collections	4
Construction	5
Coordinating Furnishings	6
Signature Services	8
New Water Cooler Box Design	10

Our Collections

Great Lakes	12
Keystone-nu	38
Keystone	54
Ipe & Keystone-Ipe	72
Birkdale-Ipe	98
Roofs & Umbrellas	108

Categories

Tee Markers	114
Tee Signs	124
Signs	136
Champion™ Ball Washers	150
Accessories	156

Off Course Areas

Swimming Pool Furnishings	164
Bag Drop	170
Driving Range	182

Add'l Online Offerings/Collections	194
Replacement Parts	110
Sales Policies	113





Our Collections

Six Styles to Match Any Taste.

Before you begin envisioning how your new driving range or bag drop area, pick a collection that identifies with your course. Prestwick Golf Group offers 6 distinct styles for you to choose from. Material options range from recycled plastic, hardwood, or a combination of both – any look that's sure to compliment your course's decor.

Forever·nu™ Lumber

made from 98% pure recycled HDPE plastic



Great Lakes
Forever·nu™ Trim & Panels



Keystone·nu™
Forever·nu™ Trim & Panels
with Keystone Accents



Keystone
Ipe Trim & Forever·nu™ Panels
with Keystone Accents

Ipe Hardwood

responsibly harvested/solid hardwood construction



Ipe
Ipe Trim & Panels



Keystone-Ipe
Ipe Trim & Panels
with Keystone Accents



Birkdale
Ipe Trim & Panels
with Metal Grid Accents

Uncompromising Standards



Compromising is not an Option.

We often wonder how our competitors believe they can provide you with a better product at half the quality. A Prestwick furnishing cannot be duplicated because of the indispensable standards set for each and every product. From material quality to craftsmanship and hardware selection, only Prestwick Golf Group can provide you with products you can be proud of, beyond the money you'll still have left in your pocket.

How Prestwick Standards Measure Up vs. Competitors

ks-drse

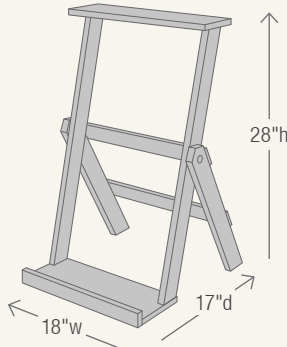

ks-po3

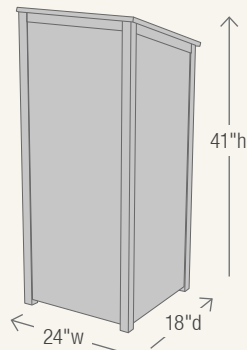

ks-gbr5

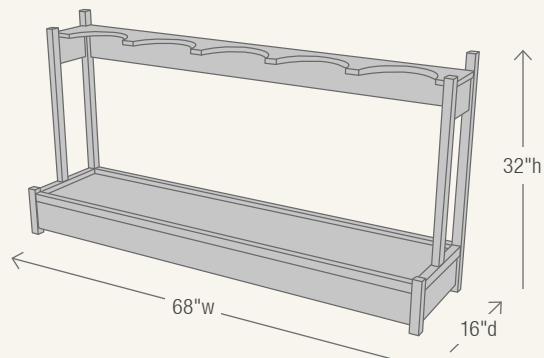

No Shortcuts with Prestwick

Our commitment to quality manufacturing shows up in the details of our products:

- **Marine Grade Hardware** – marine grade stainless steel hinges and fasteners will help prevent your door swings from getting rusty.
- **Pocket-Screw Construction** – assembled from the inside out. This hidden joint style is one of the strongest available.
- **Plugged Screw Holes** – a characteristic of true craftsmen.
- **Solid Hardwood Construction** – products that are built to last, with solid profiles that rival other competitors and won't buckle under pressure.
- **Two-Part Wood Preservation** – our two-part, hand-applied wood preservation system is standard on all Ipe products. Furnishings may be allowed to weather or can be re-treated to maintain their original rich appearance with no sanding or sealing.



Coordinate

What One Seamless Look Says About your Property.

Once you've chosen a collection, coordinate that look throughout your course. A consistent product line from tee to green elevates the experience you aim to provide for guests. It's an investment they'll likely not overlook – nor shy away from.



Double Towel Valet



Sideload Waste Enclosure



Large Cooler Box



Backless Bench



Round Waste Enclosure



Double Recycle Station



Storage Box



Combination Station



Bag Stand

Driving Range



Bag Drop



Course Area





Signature Service

Let us Help Strengthen your Brand.

We know you've worked hard establishing a brand identity that resonates with your customers – our signature service options help serve as an extension of that effort. Adding a visual identity to course furnishings makes a strong statement about the character and quality of your establishment; an impression your customers will remember long after their visit.

Decal Options



*Inlaid Logo
(in Forever-nu™ panel)*



*Inlaid Logo
(in Ipe frame)*



*Inlaid Logo
(on Forever-nu™ plaque)*

Engraved Options



*Engraved Logo
(in Forever-nu™ panel)*



*Engraved Logo
(on Ipe plaque)*



*Engraved Logo
(on Ipe Keystone)*

Metal Options



Laser-Cut Metal Logo



*Cast Metal Medallion
with Inlaid Logo*



Cast Metal Medallion



10
PAR 4

RED LEDGES
18
PAR 4

RED LEDGES
18
PAR 4



Thinking inside the box

We've put a lot of thought into our new Cooler Box – so you won't have to.

Our new Cooler Box has a lot to offer. Constructed with a liner molded from FDA-Approved plastic (#4 recyclable), this product exemplifies our rigid standards in research and engineering. Each liner allows for easy cleaning and removal of ice, while the secure seal on the lid guarantees refreshments to stay cool for days at a time.

Applicable in Every Way

Whatever you decide to fill it with, our new Cooler Box will keep it fresh throughout the day.



Configure Creatively

The flexibility of a WBB40 liner allows creation of up to 4 divisions for a variety of different snacks, beverages, or towels.

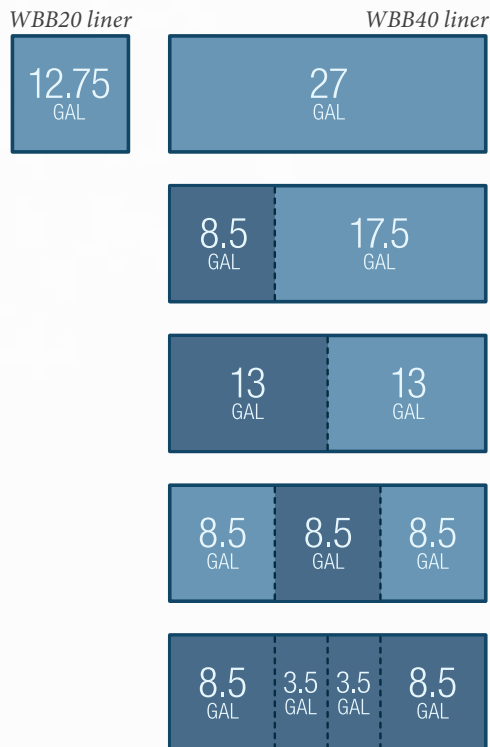

FDA-Approved Plastic = Advantage Prestwick

How a liner molded from FDA-Approved plastic can give us a significant edge over what competitors offer:

- **Anti-Bacterial** – Each liner contains a special additive applied directly to the plastic that prevents bacteria growth.
- **Stain-Resistant** – Wipe up spills with ease; stains won't stick around.
- **Mold & Mildew Free** – Similar to our own Forever-nu™ Lumber, this plastic prevents mold and mildew from growing on the liner.
- **No Transferred Chemicals** – Unlike other plastics, this liner's chemical composition will not leech into any stored food or ice.

A WBB40 liner can hold items such as:

- 60+ Water Bottles
- 50+ Hand Towels
- 100+ Apples
- 60+ lbs of Ice



1

2

3

4

5

6

- 1 *Marine-Grade Hardware*
- 2 *FDA-Approved Plastic*
- 3 *Insulation Liner*
- 4 *Forever-nu™ Lumber Panel*
- 5 *Drain Plug*
- 6 *Solid Hardwood Construction*